



AUTOMATED MOUNTING SOLUTIONS

flat panel tv and projector



Chief's state-of-the-art Automated Projector and Flat Panel TV mounts combine top-quality mounting solutions with fully motorized, remote operation. These mounts offer programmable viewing angles and fast, fine-tuned adjustments.

www.chiefmfg.com



AUTOMATED MOUNTING SOLUTIONS

FLAT PANEL MOUNTS

MOUNTS IN MOTION

Introducing Chief's new Automated Swing Arm Wall Mount

Chief is powering up one of our most popular swing arm solutions! The all-new PXR™ automated Swing Arm Wall Mount includes all of the functionality of the PNR™ Swing Arm Mount, in a fully automated version with programmable remote control.



FEATURES (CME26U shown)

- 1 LOW PROFILE**
Collapses to 4.5" (114 mm), concealing mount behind the screen
- 2 EXTENDS UP TO 26" (660 mm)**
Full extension to maximize viewing potential
- 3 SMOOTH TILT & SWIVEL**
Provides up to 90° of swivel, and up to 15° of tilt for optimal viewing
- 4 CABLETRAC™ SYSTEM**
Channeled cable management provides quick and easy routing of cables
- 5 IR REMOTE**
Includes 4 programmable preset buttons

AUTOMATED MOUNTING SOLUTIONS

AUTOMATED SERIES



PXRU
Automated Flat Panel TV Wall Mount

New

OPTIONAL ACCESSORY



PAC502™
In-Wall Box for
No-Profile
Installations

Available Soon!



CM2C40U / CM2L40U
Automated Flat Panel TV Lifts



CM8T15U
Automated Flat Panel TV Tilt Wall Mount

SPECIFICATIONS

Model	TV Size Range	Depth from Wall	Extension	Swivel	Tilt*	Max Mounting Pattern (H,W)	Weight Capacity
Cinematic Series Swing Arm Mounts							
PXRUB™	42 - 65"	4.5" (114 mm)	26" (660 mm)	L: 45° R: 45°	U: 0° D: 15°	H: 17.75" (450 mm), W: 27.4" (695 mm)	200 lbs (90.7 kg)
CM2C40U™	32 - 61"	–	31 - 71" (79 - 180 cm)	–	–	H: 20.37" (517 mm), W: 39.93" (101.4 cm)	190 lbs (86.2 kg)
CM2L40U™	32 - 61"	–	31 - 71" (79 - 180 cm)	–	–	H: 20.37" (517 mm), W: 39.93" (101.4 cm)	190 lbs (86.2 kg)
CM8T15U™	37 - 60"	3.6" (91 mm)	–	–	U: 2° D: 13°	H: 19.3" (490 mm), W: 30.1" (765 mm)	150 lbs (68 kg)

*Varies with screen height.



AUTOMATED MOUNTING SOLUTIONS

PROJECTOR LIFTS

Chief's automated projector lifts provide smooth and quiet lift technology for concealed installations. Both models are fully enclosed and offer either 8.5" or 36" of extension.

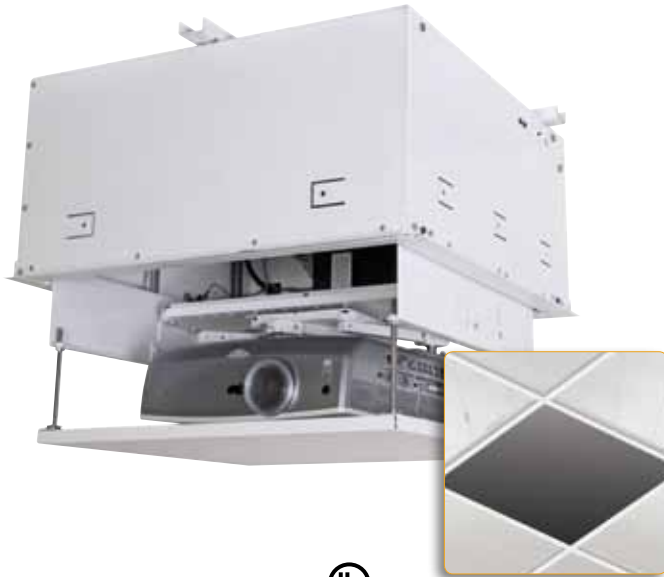

Now fits into 2' x 2' (600 x 600 mm) ceiling tile, with up to 8.5" (216 mm) extension



Automated Projector Lift with up to 36" of Extension

SPECIFICATIONS

Model	Extension	Max Projector Size (HxWxD)	Ceiling Opening (HxWxD)	Ceiling Closure (WxD)	Roll/Pitch/Yaw	Weight Capacity	Color
Cinematic Series Swing Arm Mounts							
SL151™	8.5" (216 mm)	8.38 x 18 x 18.25" (213 x 457 x 464 mm)	11.25 x 23 x 22.75" (286 x 584 x 578 mm)	20.25 x 20.25" (514 x 514 mm)	±2°, ±20°, ±5°	35 lbs (15.9 kg)	White
SL236™	36" (914 mm)	9.25 x 20.5 x 22.75" (279 x 635 x 698 mm)	25.5 x 28" (41 x 710 mm)	24 x 24" (610 x 610 mm)	±2°, ±15°, ±5°	35 lbs (15.9 kg)	White

For more information on these and other products from Chief, the industry leader in AV mounting solutions, visit www.chiefmfg.com.

end-user focused

faster installation

superior service

proven quality

CHIEF MANUFACTURING

■ A DIVISION OF MILESTONE AV TECHNOLOGIES ■ www.chiefmfg.com

Milestone AV Technologies

■ P 800.582.6480/952.894.6280 ■ F 877.894.6918/952.894.6918 ■ chief@chiefmfg.com

Chief Mounts Canada

■ P 877.345.4329 ■ F 888.377.5314 ■ info@chiefmounts.ca

Milestone AV Technologies B.V.

■ P +31 40 23 24 700 ■ F +31 40 23 24 710 ■ europe.chief@milestone.com

Milestone AV Technologies Ltd

■ P +852 2145 4099 ■ F +852 2145 4477 ■ asia.chief@milestone.com

©2009 Milestone AV Technologies, a Duchossois Group Company. 900145A 8/09. Chief is a registered trademark of Milestone AV Technologies. All other brand names or marks are used for identification purposes and are trademarks of their respective owners. All patents are protected under existing designations. Other patents pending.